

- HEADER AND REAR COLUMNS TO BE PREPPED WITH PULL STRING.

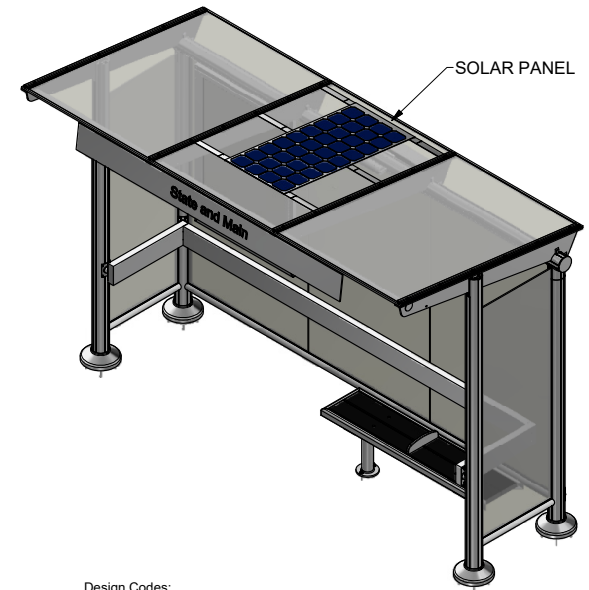

Design Codes:
 o 2018 Virginia Uniform Statewide Building Code: (2018 VUSBC)
 o 2018 Virginia Construction Code: Part I of the VUSBC (2018 VCC)
 o Handicapped Accessibility: 2010 ADA Standards for Accessible Design - 9/15/2010 (2010 ADA Standards for the Prototype Bus Shelter and mounting floor slab.
 o Accessibility Guidelines for Pedestrian Facilities in the Public Right of Way: Public Rights-of-Way Accessibility Guidelines - 7/26/2011 (PROWAG). Required for the site adaptation approaches to the Prototype Bus Shelter.
 o Per CPSM 4.2.2, including 4.2.2.8: accessible facilities must be provided at the completion of construction. Additionally, per CPSM 4.2.2.8; all areas and spaces normally occupied by employees or the public in state-owned buildings, individually or shared, shall be fully accessible.
 Structural Design Data
 o Roof Live Load, per VUSBC 1603.1.2; 20 psf
 o Floor Live Load, per VUSBC 1603.1.1; 100 psf
 o Roof Snow Load Data, per VUSBC 1603.1.3; 25 psf
 o Wind Design Data, per VUSBC 1603.1.4 - Wind Speed (mph); (Ultimate Wind Speed) 111mph
 o Wind Exposure Category; C
 o Risk Category, per VUSBC 1604.5; II
 o Seismic Design Category B The following calculations have
 o Seismic Site Class D been prepared by me or under
 o Soil bearing requirements 1500 psf my direct supervision
 o VUSBC Construction Type; IIB
 o (Use) Group(s) per VUSBC; U
 o Building Gross Floor Area 26 SF
 o Building Area (per VUSBC definition) 26 SF
 o Height of Building; 8 ft
 o Number of Stories; 1 Story
 o Construction Type - Type IIB
 o Occupancy Classification - Group U

CONCRETE THICKNESS: 6"
 CONCRETE PAD LENGTH: 13'-6"
 CONCRETE PAD WIDTH: 5'-6"
 REINFORCEMENT: #4 @ 16" EW

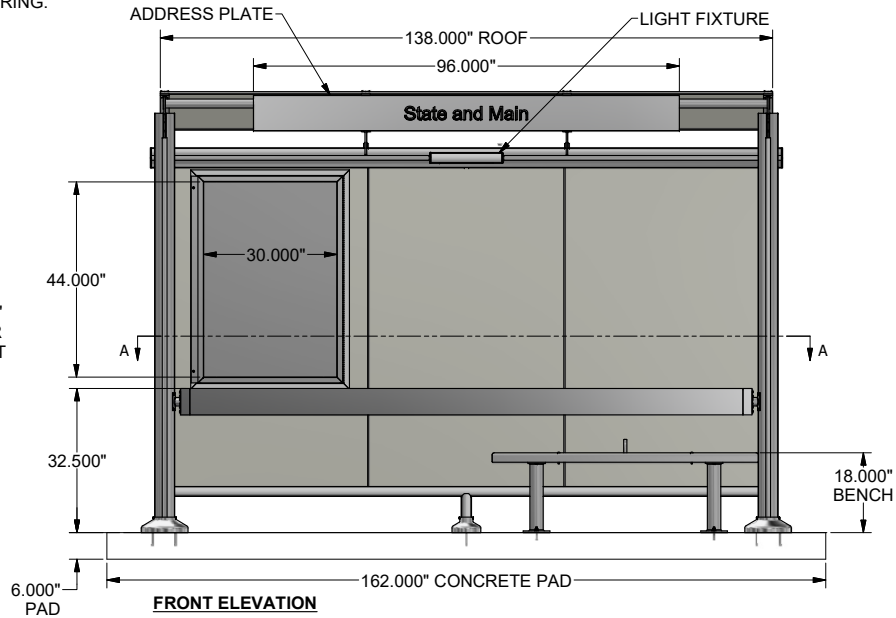
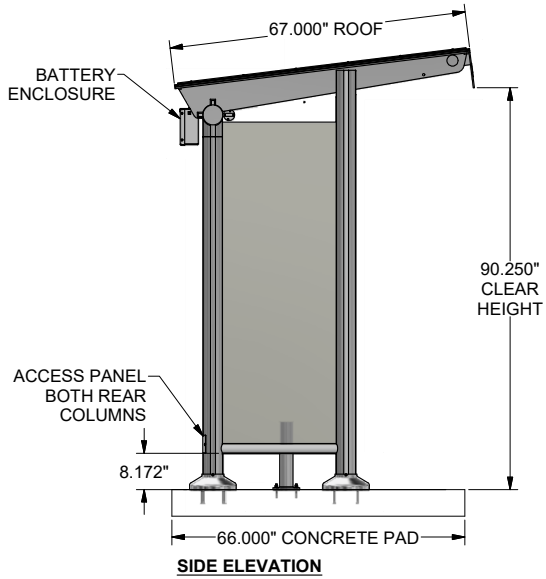
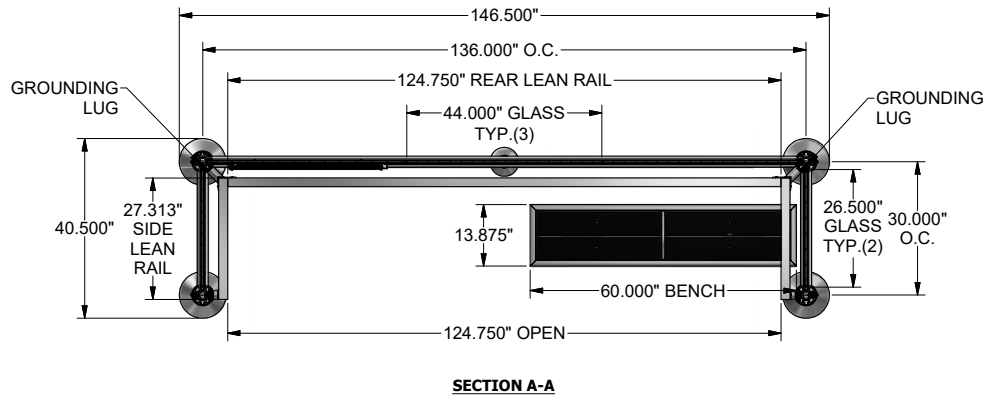

QUANTITY (XX) SHELTERS THUS

SPECIFICATIONS:

- RAL9017 TRAFFIC BLACK POWDER COATED ALUMINUM STRUCTURE
- 3/8" CLEAR LAMINATED SAFETY GLASS
- 5' ECLIPSE BENCH WITH BLACK HDPE SLATS AND (1) SEAT DIVIDERS
- 30" x 44" VIEWABLE DISPLAY CASE (REAR WALL)
- 2" x 6" ALUMINUM LEAN RAIL (INTERIOR)
- SPUN ALUMINUM ANCHOR PLATE COVERS
- 96" ALUMINUM ADDRESS PLATE WITH VINYL GRAPHIC (T.B.D.)
- 3/8" GREY POLYCARBONATE SLOPED ROOF
- SOLAR POWERED LIGHTING PACKAGE WITH L.E.D. LIGHT FIXTURE AND BATTERY ENCLOSURE

	BRASCO INTERNATIONAL, INC. 32400 INDUSTRIAL DR. MADISON HEIGHTS, MICHIGAN 48071 1-800-893-3665 WWW.BRASCO.COM		CUSTOMER:	CITY OF ALEXANDRIA	DESIGNER:	HAUS	CHECKER:	BDH
	THIS DRAWING IS CONFIDENTIAL AND IS FOR THE SOLE USE OF OUR CUSTOMERS AND MAY NOT BE REPRODUCED OR COPIED WITHOUT WRITTEN PERMISSION FROM BRASCO INTERNATIONAL.		PROJECT:	ECLIPSE STYLE SHELTER	DATE:		DATE:	
MODEL:			EC-0512-C-0-FL-PC-LG-0-0-0	JOB #	6899	SHEET:	S-001	REVISION:

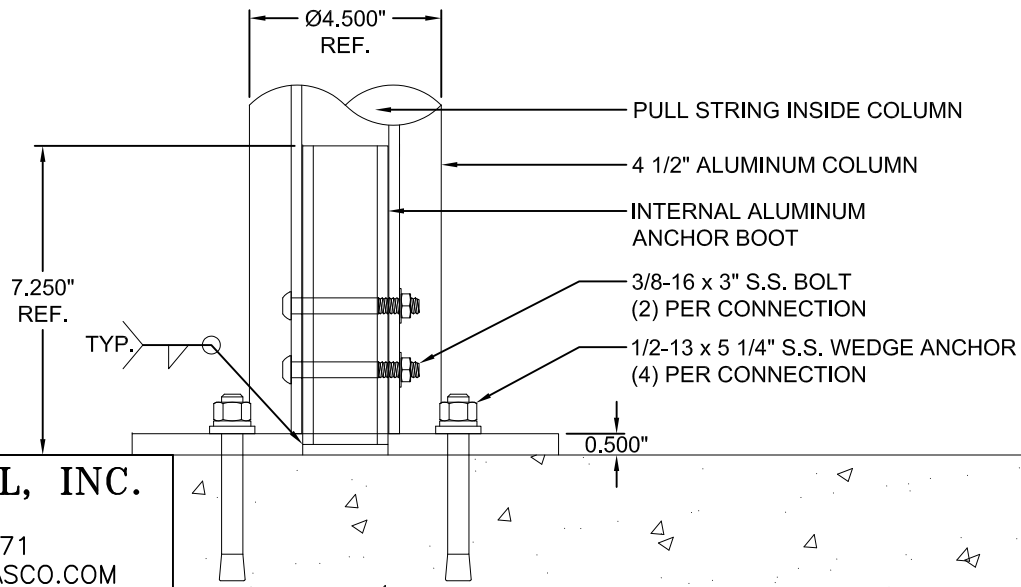
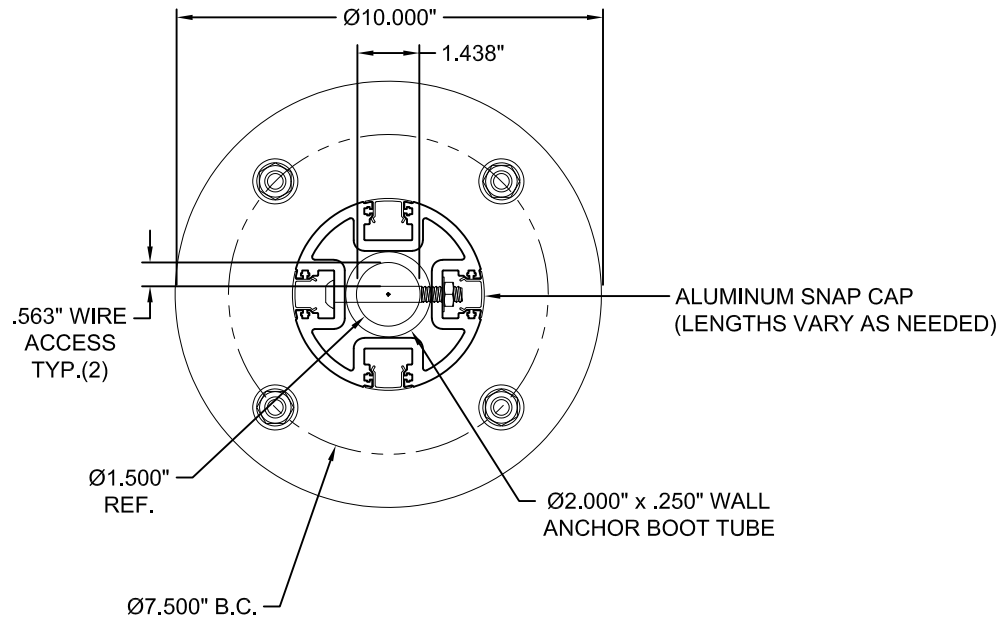

BRASCO INTERNATIONAL, INC.
 32400 INDUSTRIAL DRIVE
 MADISON HEIGHTS, MI 48071
 1-800-893-3665 WWW.BRASCO.COM

THIS DRAWING IS CONFIDENTIAL AND IS FOR THE SOLE USE OF OUR CUSTOMERS AND MAY NOT BE REPRODUCED OR COPIED WITHOUT WRITTEN PERMISSION FROM BRASCO INTERNATIONAL.
LEAD TIME BEGINS UPON RECEIPT OF SIGNED APPROVAL.

SIGNED: _____ DATE: _____

CUSTOMER:		ENGINEER:	HAUS
DETAIL:	SHELTER ANCHORING	DATE:	
MODEL:	ECLIPSE SERIES	JOB #	6899
		SHEET #:	002

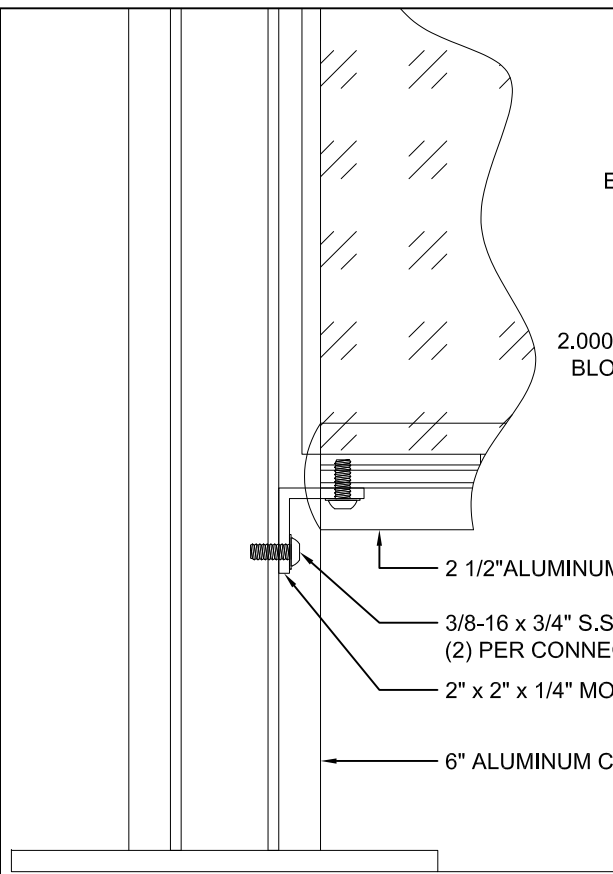

VIEW AT COLUMN CONNECTION

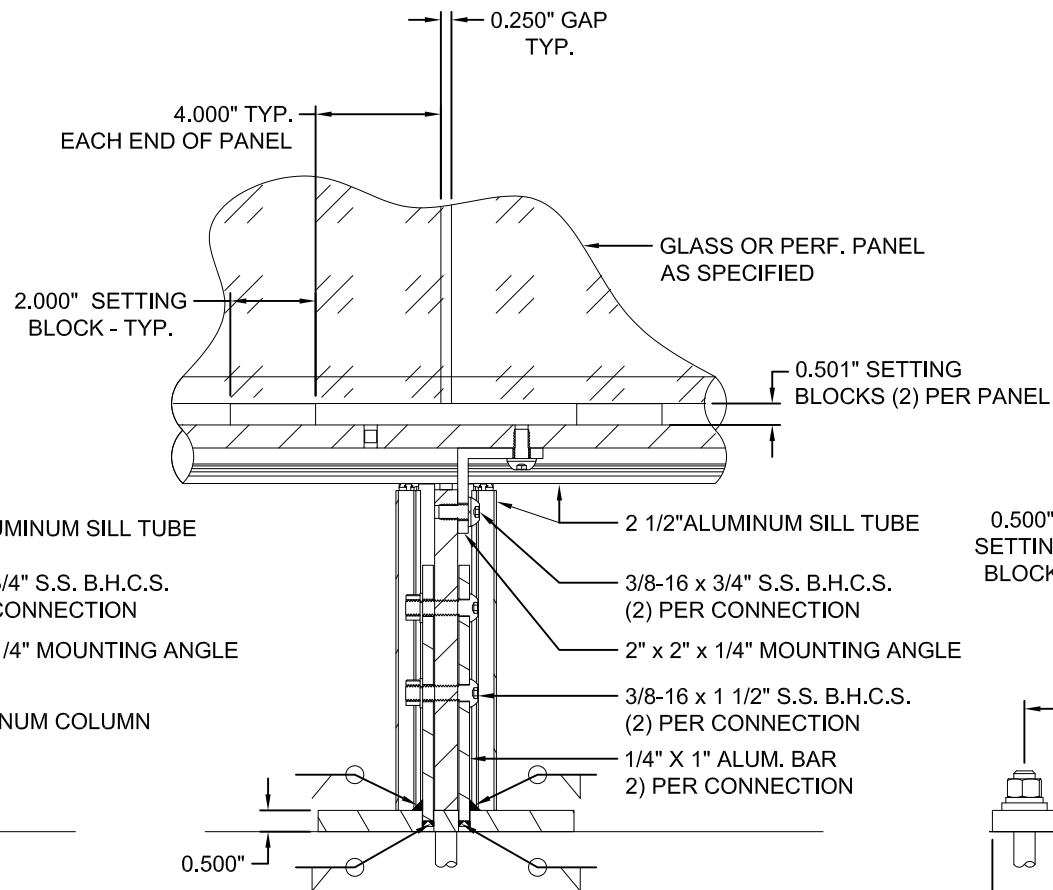

FRONT VIEW AT SILL SUPPORT

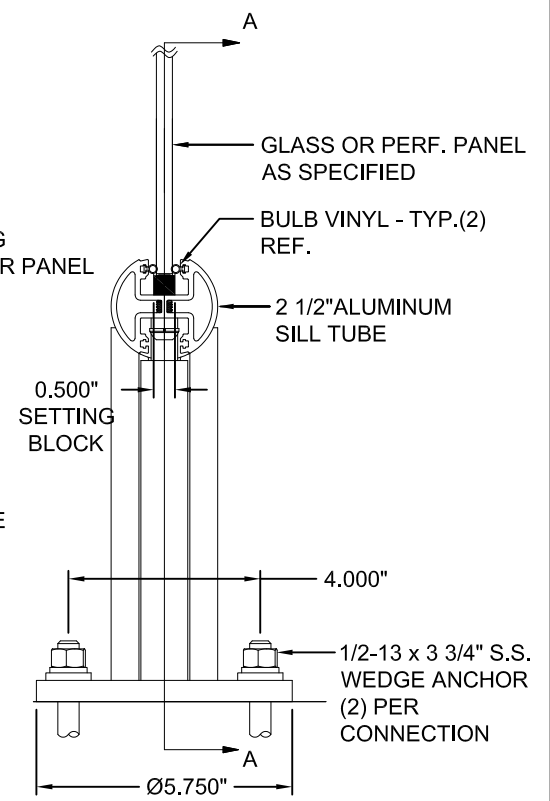

SIDE VIEW AT SILL SUPPORT

BRASCO INTERNATIONAL, INC.

32400 INDUSTRIAL DRIVE
 MADISON HEIGHTS, MI 48071
 1-800-893-3665 WWW.BRASCO.COM

THIS DRAWING IS CONFIDENTIAL AND IS FOR THE SOLE USE OF OUR CUSTOMERS AND MAY NOT BE REPRODUCED OR COPIED WITHOUT WRITTEN PERMISSION FROM BRASCO INTERNATIONAL.
LEAD TIME BEGINS UPON RECEIPT OF SIGNED APPROVAL.

SIGNED: _____ DATE: _____

CUSTOMER:		ENGINEER:	HAUS
DETAIL:	SILL ATTACHMENT AND CONNECTIONS		DATE:
MODEL:	ECLIPSE SERIES	JOB #	6899
		SHEET #:	003

NOTE: ROOF ARRIVES FULLY ASSEMBLED

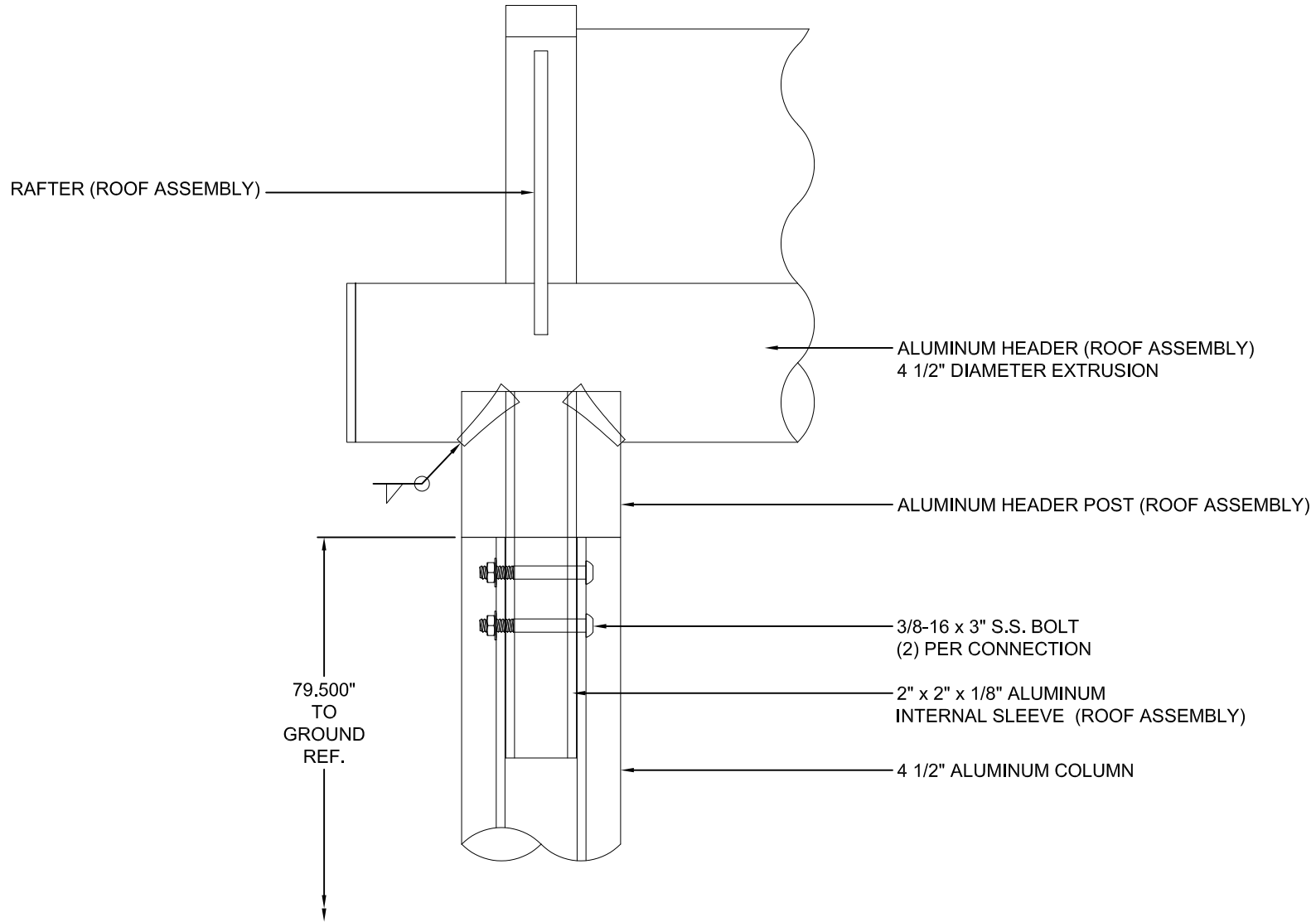

BRASCO INTERNATIONAL, INC.

32400 INDUSTRIAL DRIVE
MADISON HEIGHTS, MI 48071
1-800-893-3665 WWW.BRASCO.COM

THIS DRAWING IS CONFIDENTIAL AND IS FOR THE SOLE USE OF
OUR CUSTOMERS AND MAY NOT BE REPRODUCED OR COPIED
WITHOUT WRITTEN PERMISSION FROM BRASCO INTERNATIONAL.
LEAD TIME BEGINS UPON RECEIPT OF SIGNED APPROVAL.

SIGNED: _____ DATE: _____

CUSTOMER:		ENGINEER:	HAUS
DETAIL:	HEADER ATTACHMENT TO COLUMN		DATE:
MODEL:	ECLIPSE SERIES	JOB #	6899
		SHEET #:	004

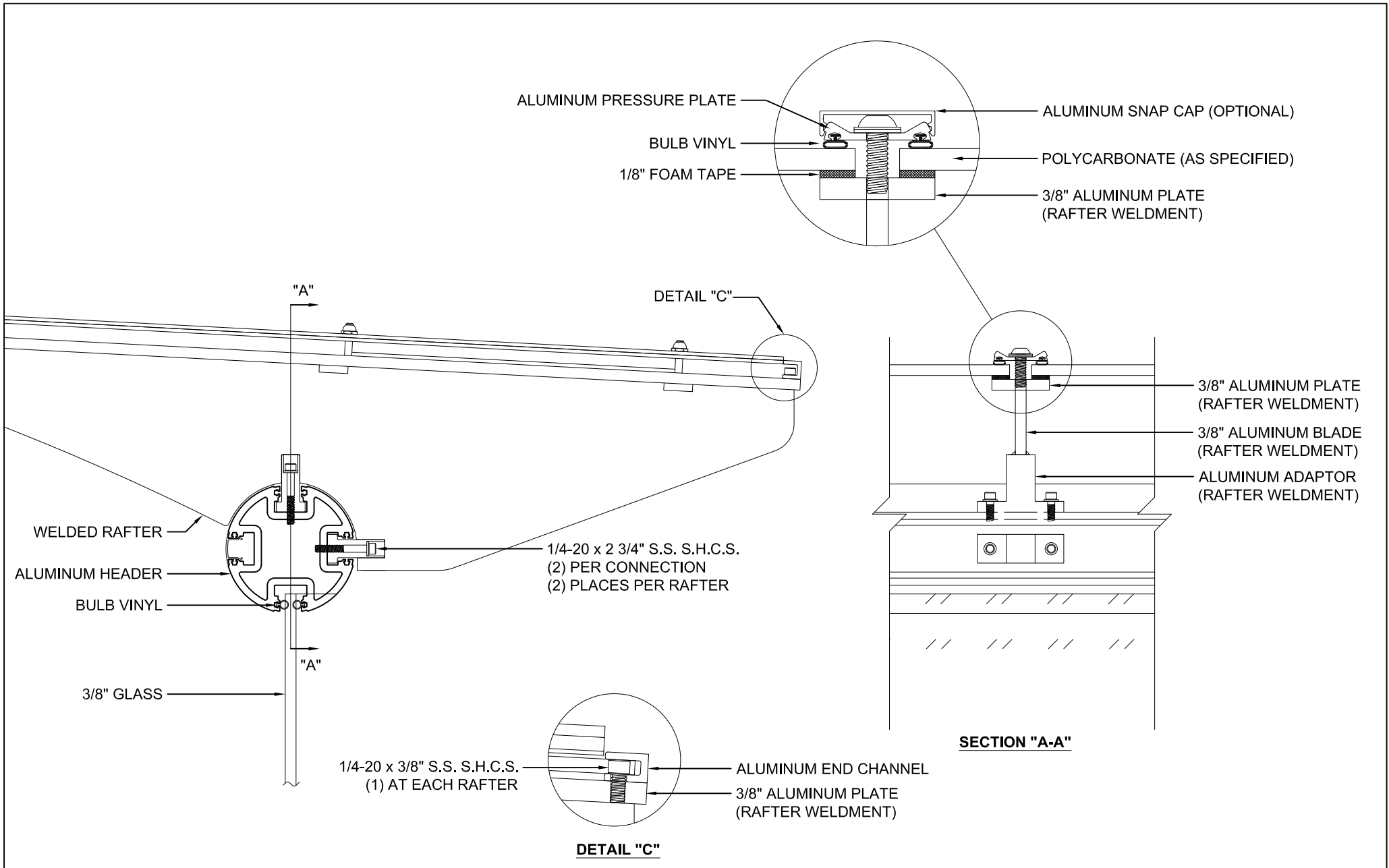

BRASCO INTERNATIONAL, INC.

32400 INDUSTRIAL DRIVE
 MADISON HEIGHTS, MI 48071
 1-800-893-3665 WWW.BRASCO.COM

THIS DRAWING IS CONFIDENTIAL AND IS FOR THE SOLE USE OF OUR CUSTOMERS AND MAY NOT BE REPRODUCED OR COPIED WITHOUT WRITTEN PERMISSION FROM BRASCO INTERNATIONAL.
LEAD TIME BEGINS UPON RECEIPT OF SIGNED APPROVAL.

SIGNED: _____ DATE: _____

CUSTOMER:		ENGINEER:	HAUS
DETAIL:	RAFTER AND ROOF ATTACHMENTS		DATE:
MODEL:	ECLIPSE SERIES	JOB #	6899
		SHEET #:	005

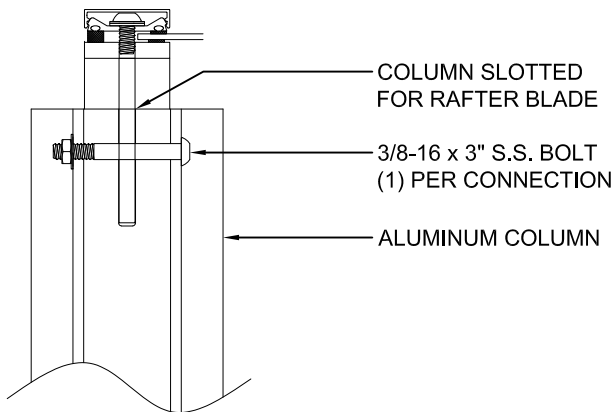
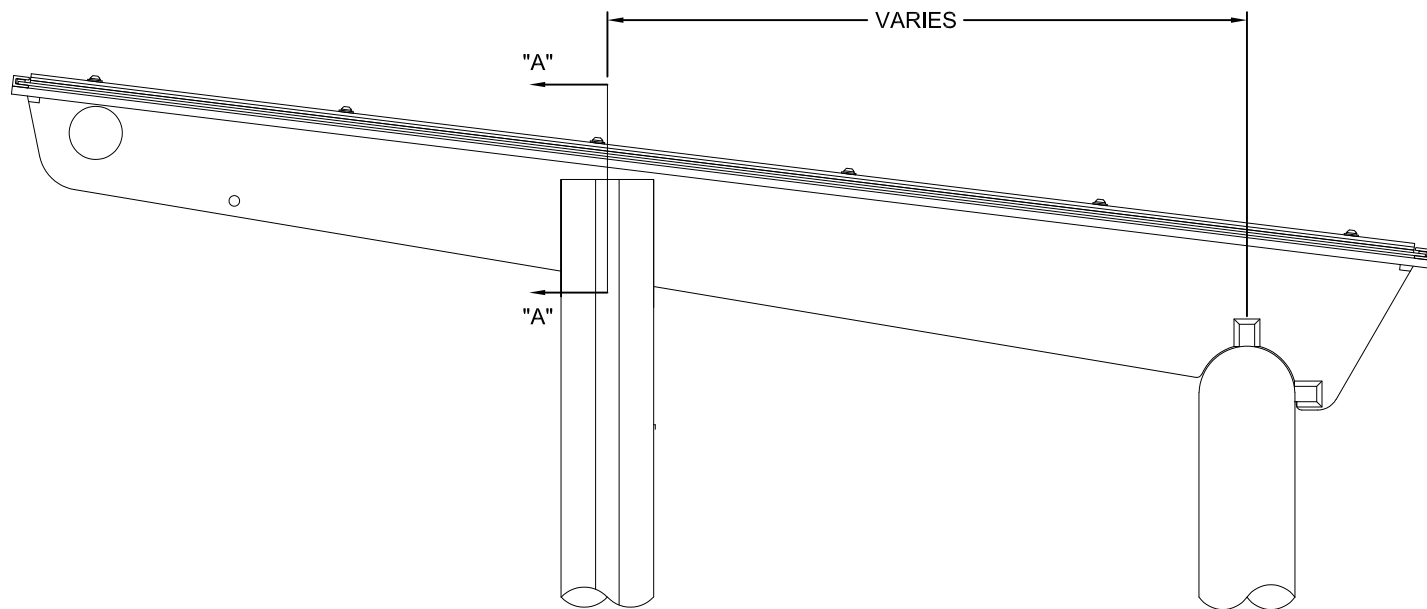

SECTION "A-A"

BRASCO INTERNATIONAL, INC.

32400 INDUSTRIAL DRIVE
 MADISON HEIGHTS, MI 48071
 1-800-893-3665 WWW.BRASCO.COM

THIS DRAWING IS CONFIDENTIAL AND IS FOR THE SOLE USE OF OUR CUSTOMERS AND MAY NOT BE REPRODUCED OR COPIED WITHOUT WRITTEN PERMISSION FROM BRASCO INTERNATIONAL.
LEAD TIME BEGINS UPON RECEIPT OF SIGNED APPROVAL.

SIGNED: _____ DATE: _____

CUSTOMER:		ENGINEER:	HAUS
DETAIL:	FRONT COLUMN TO ROOF ATTACHMENT		DATE:
MODEL:	ECLIPSE SERIES	JOB #	6899
		SHEET #:	006

SOLAR PANEL ATTACHMENT

1/4-20 x 1" S.S. B.H.C.S. WITH
WASHER & LOCK WASHER - TYP.

GASKETED PRESSURE CAP

STRAPS SECURED
UNDERNEATH PRESSURE CAPS

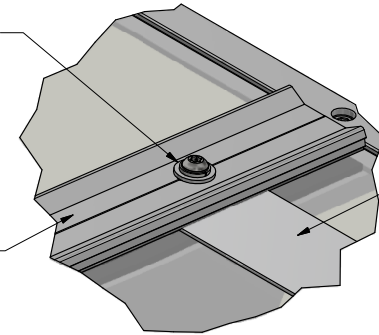

DETAIL A

.060" x 2" ALUMINUM STRAP - TYP.(3)

SOLAR PANEL SECURED TO STRAPS WITH
#10-24 CINCH STUDS AND LOCK NUTS - (6) PLACES

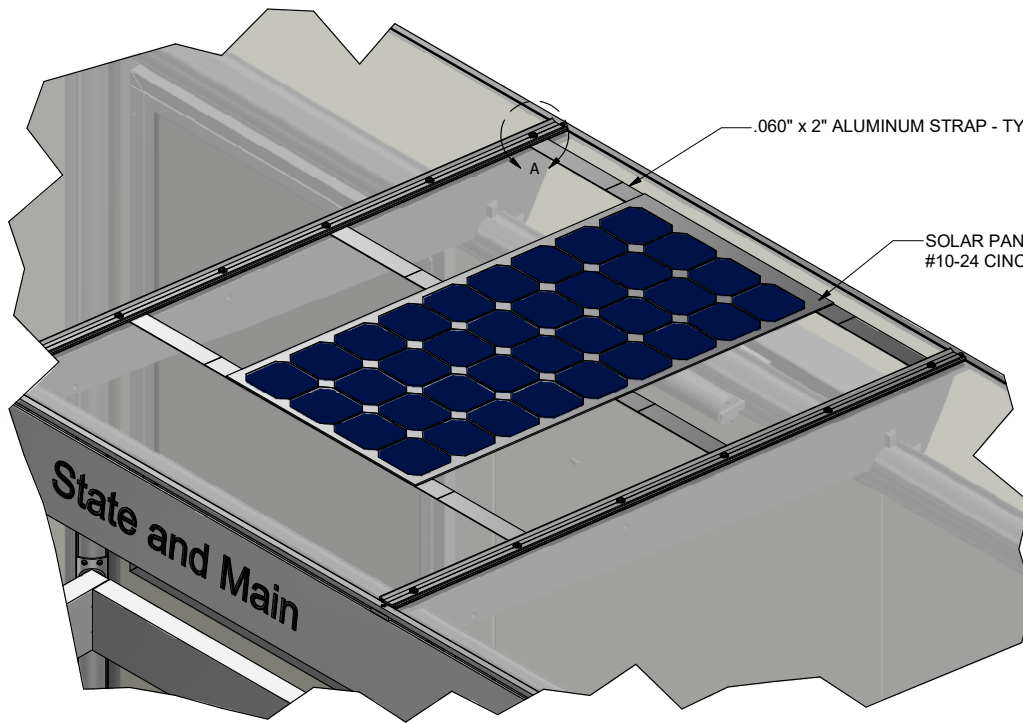

BRASCO INTERNATIONAL, INC.
32400 INDUSTRIAL DR.
MADISON HEIGHTS, MICHIGAN 48071
1-800-893-3665 WWW.BRASCO.COM

THIS DRAWING IS CONFIDENTIAL AND IS FOR THE SOLE USE OF
OUR CUSTOMERS AND MAY NOT BE REPRODUCED OR COPIED
WITHOUT WRITTEN PERMISSION FROM BRASCO INTERNATIONAL.

CUSTOMER:	CITY OF ALEXANDRIA	DESIGNER:	HAUS	CHECKER:	BDH
PROJECT:	ECLIPSE STYLE SHELTER	DATE:		DATE:	
MODEL:	SOLAR PANEL ATTACHMENT	JOB #	6899	SHEET:	007
		REVISION:			A

BATTERY ENCLOSURE AND LIGHT DETAIL

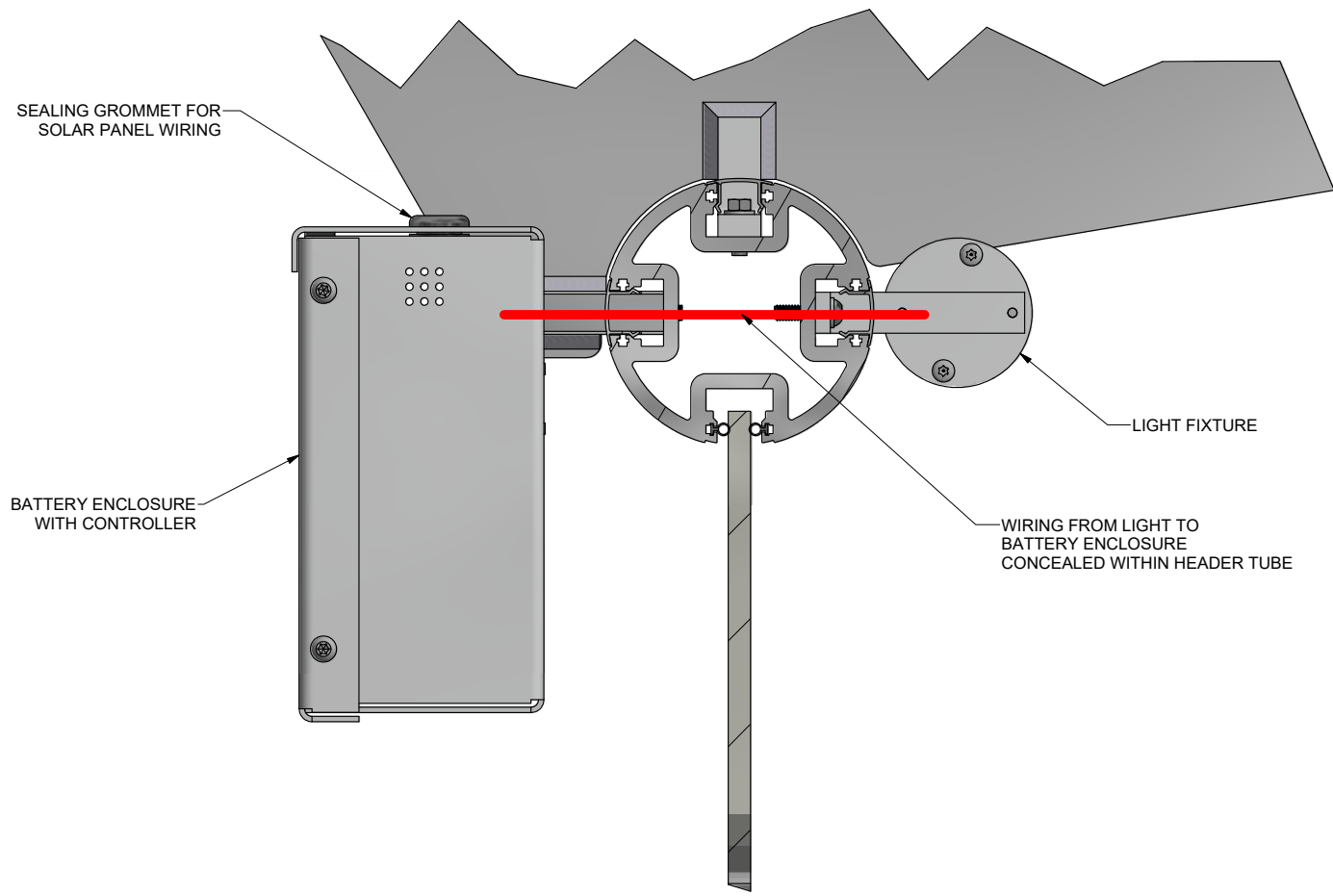

BRASCO INTERNATIONAL, INC.
 32400 INDUSTRIAL DR.
 MADISON HEIGHTS, MICHIGAN 48071
 1-800-893-3665 WWW.BRASCO.COM

THIS DRAWING IS CONFIDENTIAL AND IS FOR THE SOLE USE OF OUR CUSTOMERS AND MAY NOT BE REPRODUCED OR COPIED WITHOUT WRITTEN PERMISSION FROM BRASCO INTERNATIONAL.

CUSTOMER:	CITY OF ALEXANDRIA	DESIGNER:	HAUS	CHECKER:	BDH
PROJECT:	ECLIPSE STYLE SHELTER	DATE:		DATE:	
MODEL:	BATTERY ENCLOSURE AND LIGHT	JOB #	6899	SHEET:	008
				REVISION:	A