

Typical Retaining Wall Details Package

Based on the 2006 Virginia Construction Code

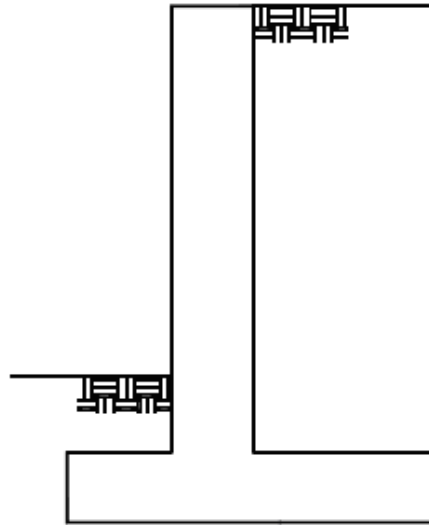

CONTENTS

Timber Retaining Wall	2
General Notes.....	2
Wall Construction	2
Deadmen Requirements	3
Connection Requirements.....	3
Masonry Retaining Wall	4
General Notes.....	4
Wall Construction	4
Bond Beam and Reinforcement Details.....	5
Dowel and Keyway Requirements.....	5
Vertical Joint Requirements	6
Backfill and Drainage Requirements.....	6
Concrete Retaining Wall	7
General Notes.....	7
Wall Construction	7
Dowel and Keyway Requirements.....	7
Vertical Joint Requirements	8
Backfill and Drainage Requirements	8
Appendix A: Contact Information	9

The use of this package in lieu of submitted drawings applies to retaining walls with the following limitations: heights no greater than 5 feet, level backfill, no surcharge loading and residential use only. Retaining walls must be constructed in strict conformance with the details contained herein. A copy of these retaining wall details is required to be on the job site and available to the inspector during the construction and inspection process. The use of the City of Alexandria Typical Retaining Wall Details for a tiered or stacked retaining wall system is strictly prohibited.

TIMBER RETAINING WALLS

GENERAL NOTES:

1. All lumber shall be 6x6, southern pine, grade #2 or better and pressure treated in accordance with American Wood-Preservers' Association standards for ground contact.
2. All spikes shall be 60d or equivalent, hot-dipped galvanized or stainless steel and driven into predrilled holes. Spikes shall be of sufficient length to penetrate the base member a minimum of 2 inches.
3. Member joints shall be staggered a minimum of 3.5 feet from the joints of the course above and below.

WALL CONSTRUCTION:

The construction of a timber retaining wall shall conform to the requirements show in FIGURE 1 through FIGURE 3.

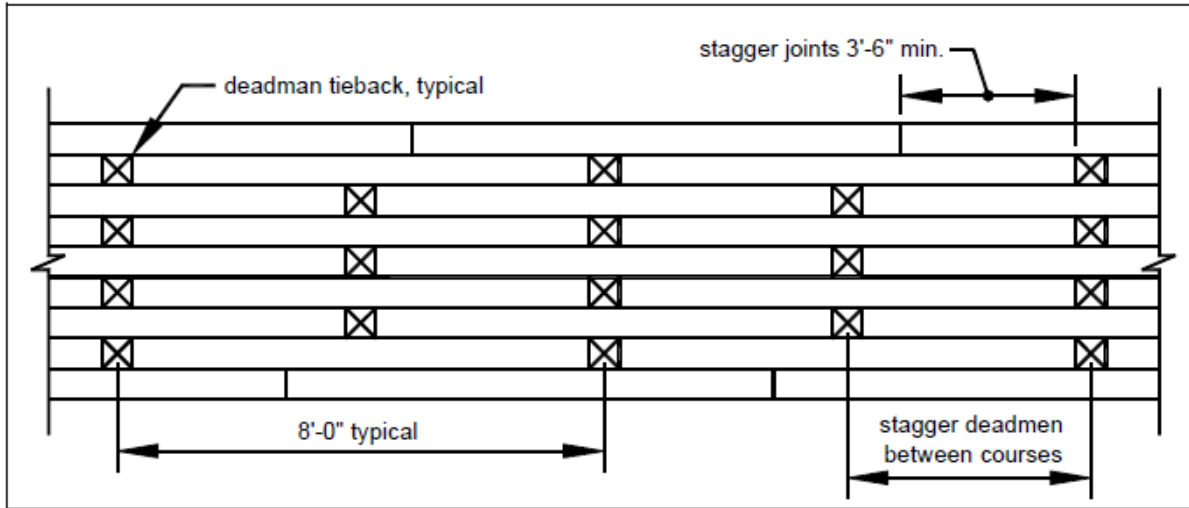

FIGURE 1: TYPICAL ELEVATION

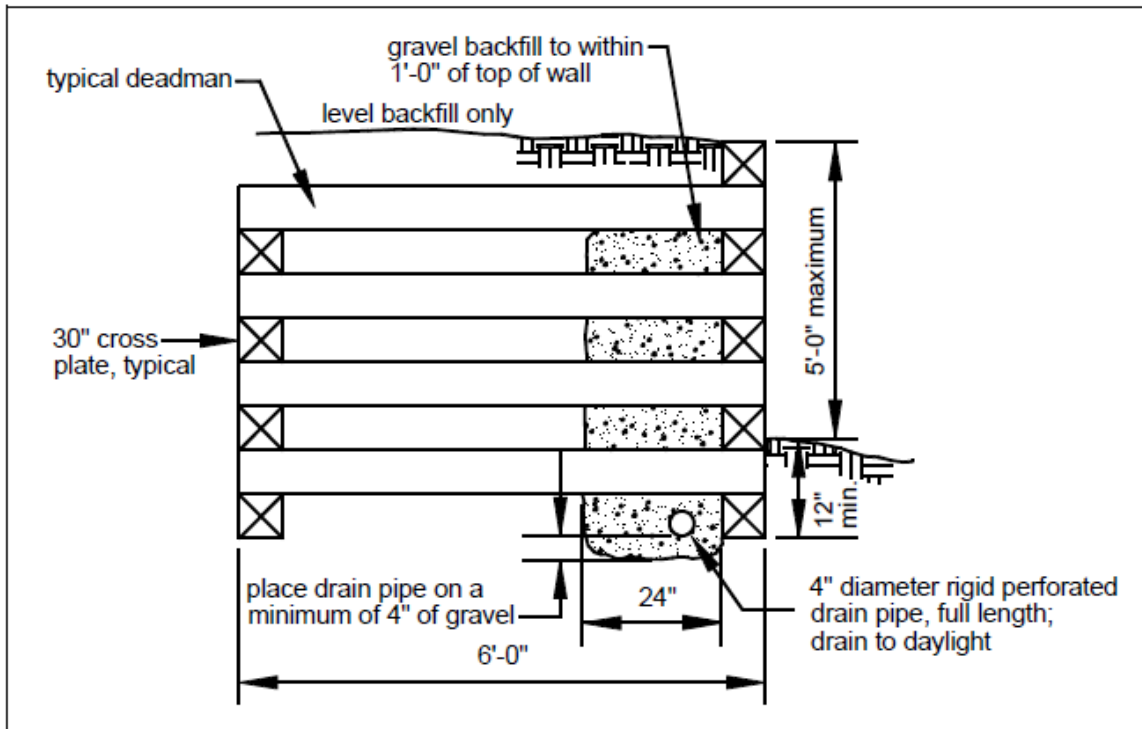

FIGURE 2: TYPICAL SECTION

DEADMEN REQUIREMENTS:

Deadmen shall be placed at 8 feet on center as shown in FIGURE 1. Deadmen and cross plates shall be constructed as shown in FIGURE 3. Deadmen are not required in the bottom course below grade.

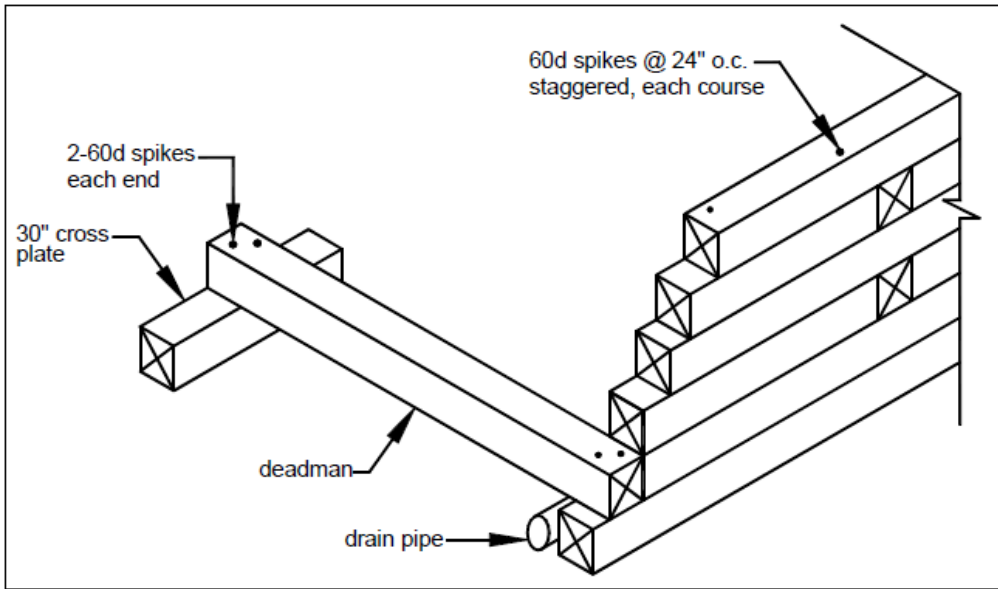

FIGURE 3: TYPICAL DEADMAN DETAIL

CONNECTION REQUIREMENTS:

Each 6x6 member shall be secured at each end with 2-60d spikes driven vertically into the member below. The corners shall be secured with 2-60d spikes and driven horizontally as shown in FIGURE 4.

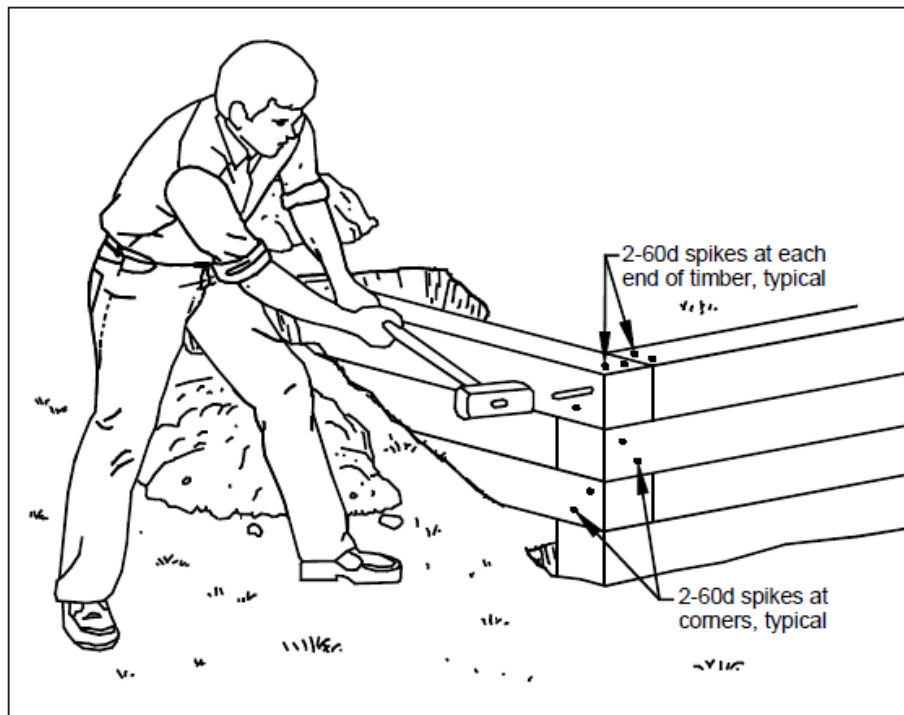

FIGURE 4: TYPICAL CORNER DETAIL

MASONRY RETAINING WALLS

GENERAL NOTES:

1. The minimum concrete compressive strength at 28 days shall be 3,500 PSI and shall comply with ACI 318.
2. Reinforcing steel shall comply with ASTM A615 and shall have a yield strength of 60,000 PSI.
3. Concrete masonry blocks shall comply with ASTM C90.
4. All joint reinforcement, ties and other accessories shall be resistant to corrosion.
5. All head and bed joints shall be 3/8-inch thick. Bed joints of the starting course over the concrete foundation may be between 1/4-inch and 3/4-inch. Mortar shall conform to ASTM C270.

WALL CONSTRUCTION:

The construction of a concrete masonry retaining wall shall conform to the dimensions and reinforcing steel requirements shown in FIGURE 5 and TABLE 1. O bars, or dowels, can be lapped above the footing in accordance with FIGURE 9.

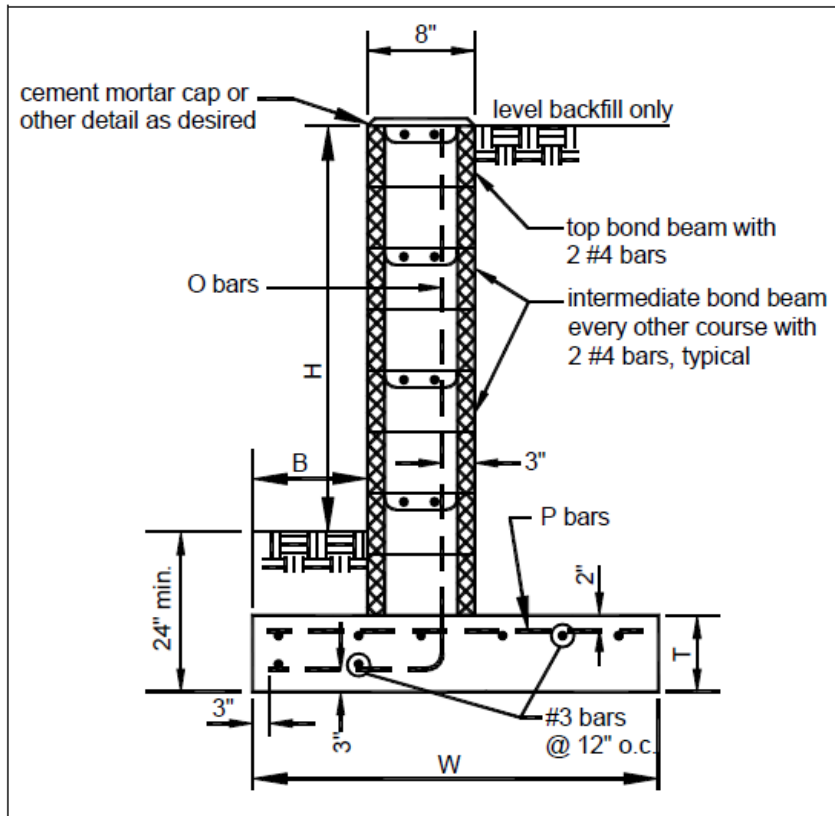

FIGURE 5: TYPICAL MASONRY WALL SECTION

TABLE 1: TYPICAL MASONRY WALL SPECIFICATIONS*

Dimensions, inches				Reinforcing Bars, inches on center	
H	B	W	T	O (dowels)	P
24	12	32	9	#3@32	#3@27
33	12	36	9	#4@32	#3@27
42	12	39	10	#5@32	#3@27
46	14	44	10	#4@16	#4@30
60	15	50	12	#6@24	#4@25

*Reference: National Concrete Masonry Association

BOND BEAM AND REINFORCEMENT DETAILS:

A bond beam shall be provided at the top course and at intermediate courses below as shown in FIGURE 5. Bond beams shall be constructed using the block types shown in FIGURE 6. Vertical and horizontal steel placement shall be per FIGURE 7 and FIGURE 8.

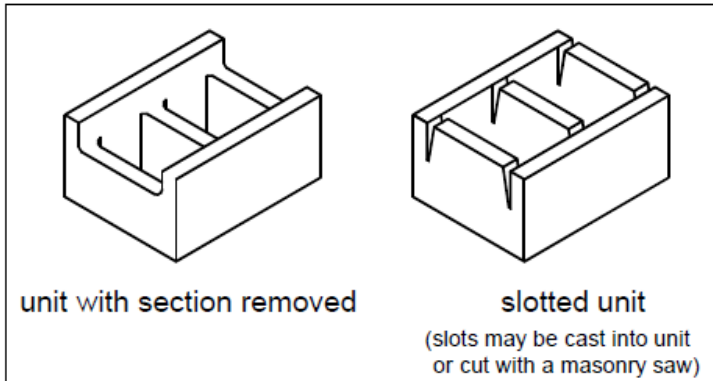

FIGURE 6: BOND BEAM BLOCK TYPE

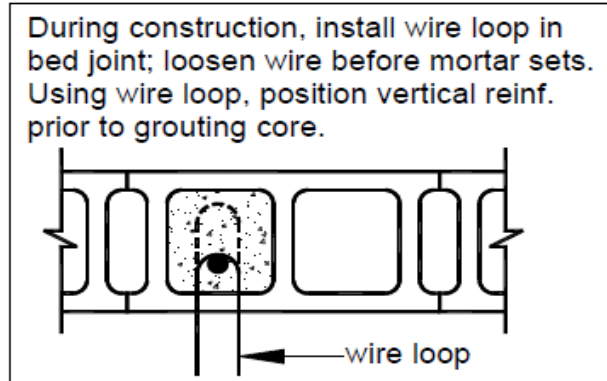

FIGURE 7: VERTICAL REINFORCEMENT

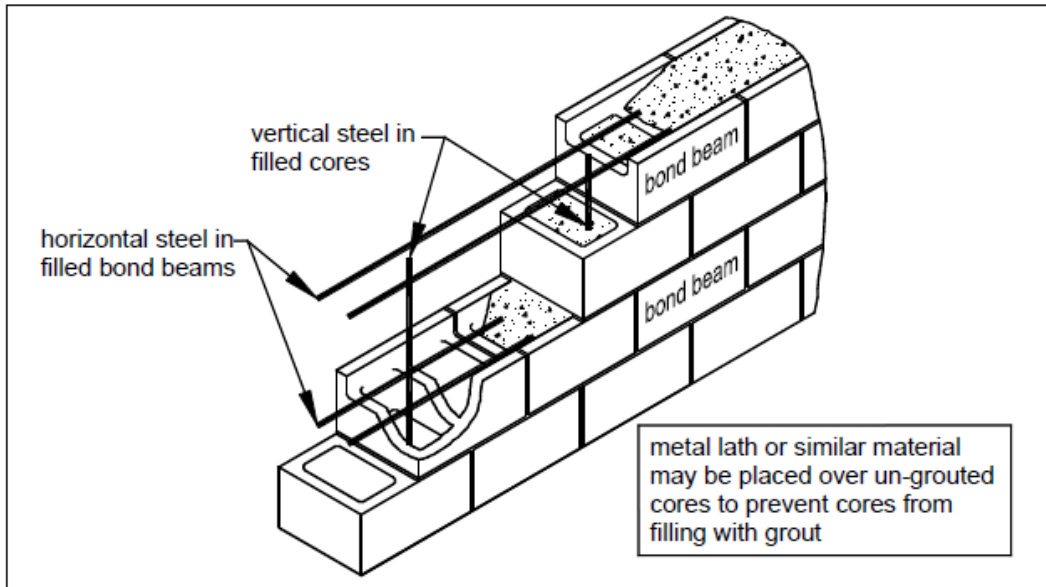

FIGURE 8: TYPICAL WALL REINFORCEMENT DETAIL

DOWEL AND KEYWAY REQUIREMENTS:

O bars, or dowels, can be lapped as shown in FIGURE 9. The minimum lap length shall be 15 inches for a #3 bar, 20 inches for a #4 bar, 25 inches for a #5 bar and 30 inches for a #6 bar. A keyway or roughened concrete shall be placed on the footing surface below the block wall; see FIGURE 9.

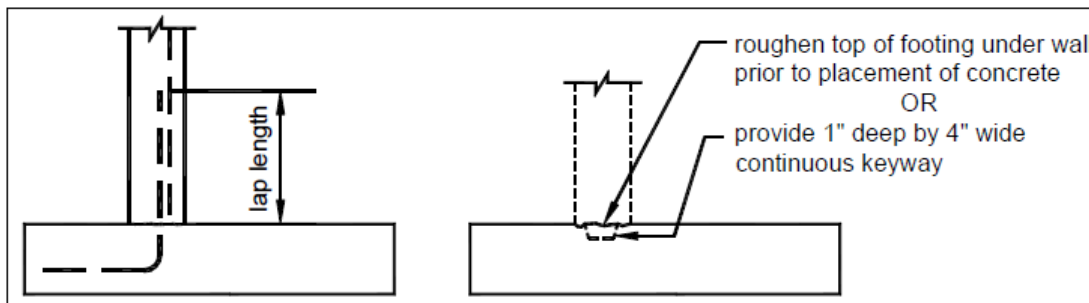

FIGURE 9: TYPICAL DOWEL AND KEYWAY DETAIL

VERTICAL JOINT REQUIREMENTS:

Control joints, constructed per FIGURE 10, shall be placed no more than 20 feet on center. Expansion joints, constructed per FIGURE 11, shall be placed at every fourth control joint.

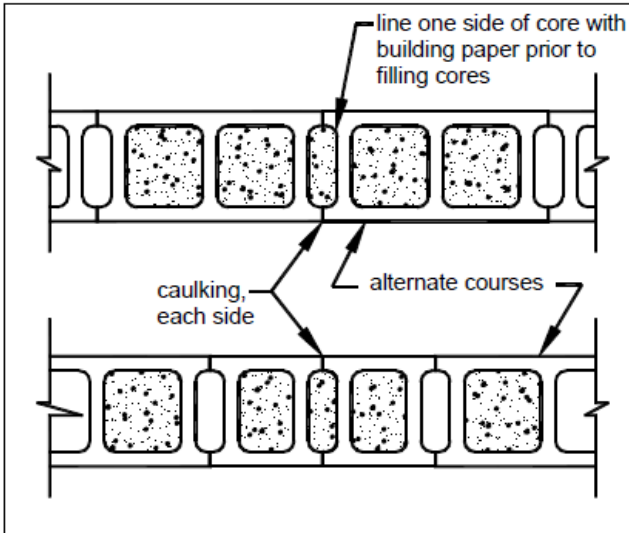

FIGURE 10: CONTROL JOINT DETAIL

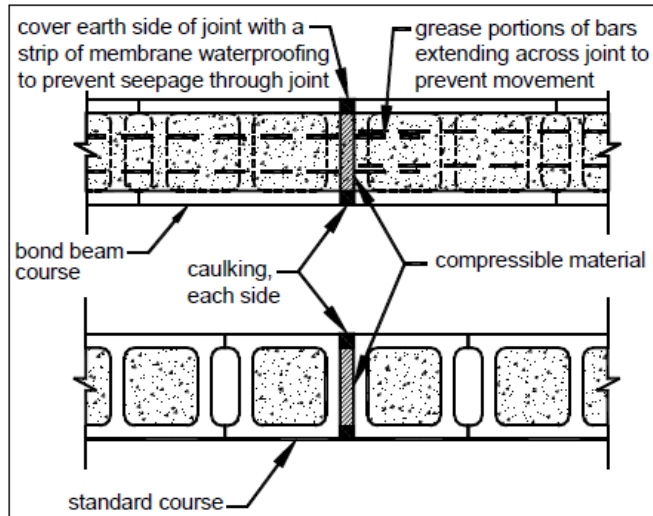

FIGURE 11: EXPANSION JOINT DETAIL

BACKFILL AND DRAINAGE REQUIREMENTS:

Backfilling against reinforced masonry retaining walls shall not be permitted until at least 7 days after placing concrete or grout in cores. Heavy equipment shall maintain a distance away from the wall equal to the wall's height. Care shall be taken to avoid exerting large impact forces on the wall.

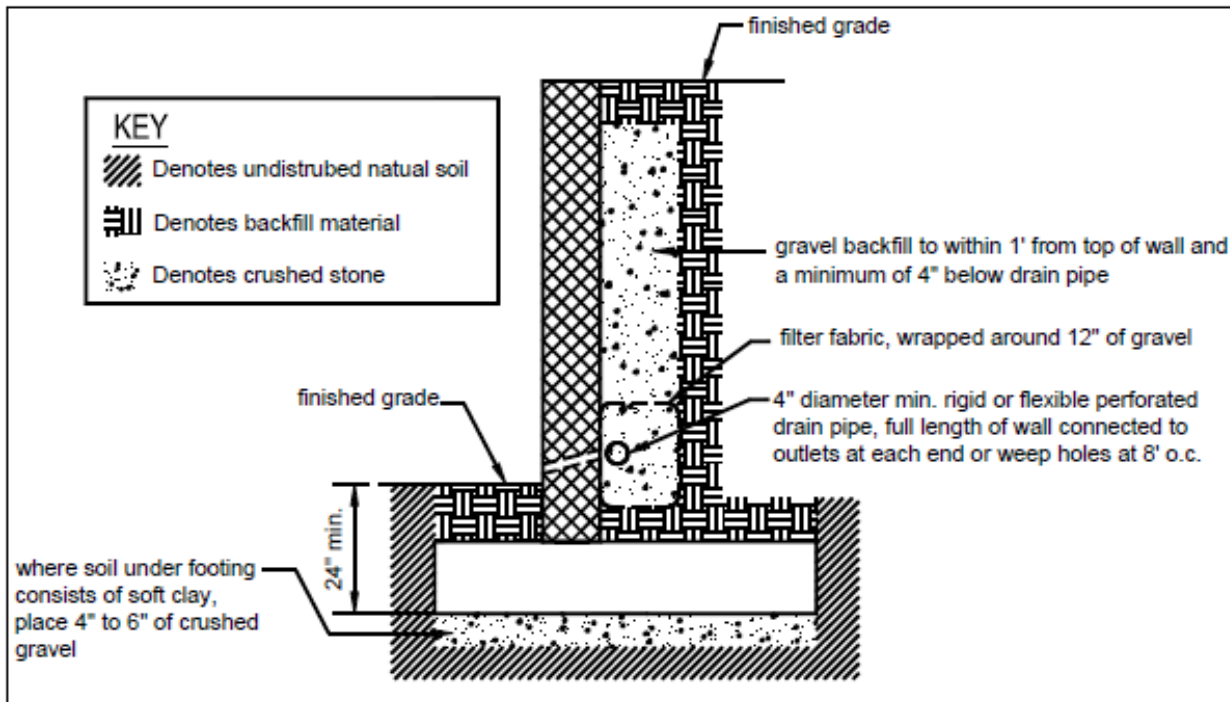

FIGURE 12: TYPICAL BACKFILL AND DRAINAGE DETAIL

CONCRETE RETAINING WALLS

GENERAL NOTES:

1. The minimum concrete compressive strength at 28 days shall be 3,500 PSI and shall comply with ACI 318.
2. Reinforcing steel shall comply with ASTM A615 and shall have yield strength of 60,000 PSI.

WALL CONSTRUCTION:

The construction of a concrete retaining wall shall conform to the dimensions and reinforcing steel requirements shown in FIGURE 13 and TABLE 2. Dowels can be lapped above the footing in accordance with FIGURE 14.

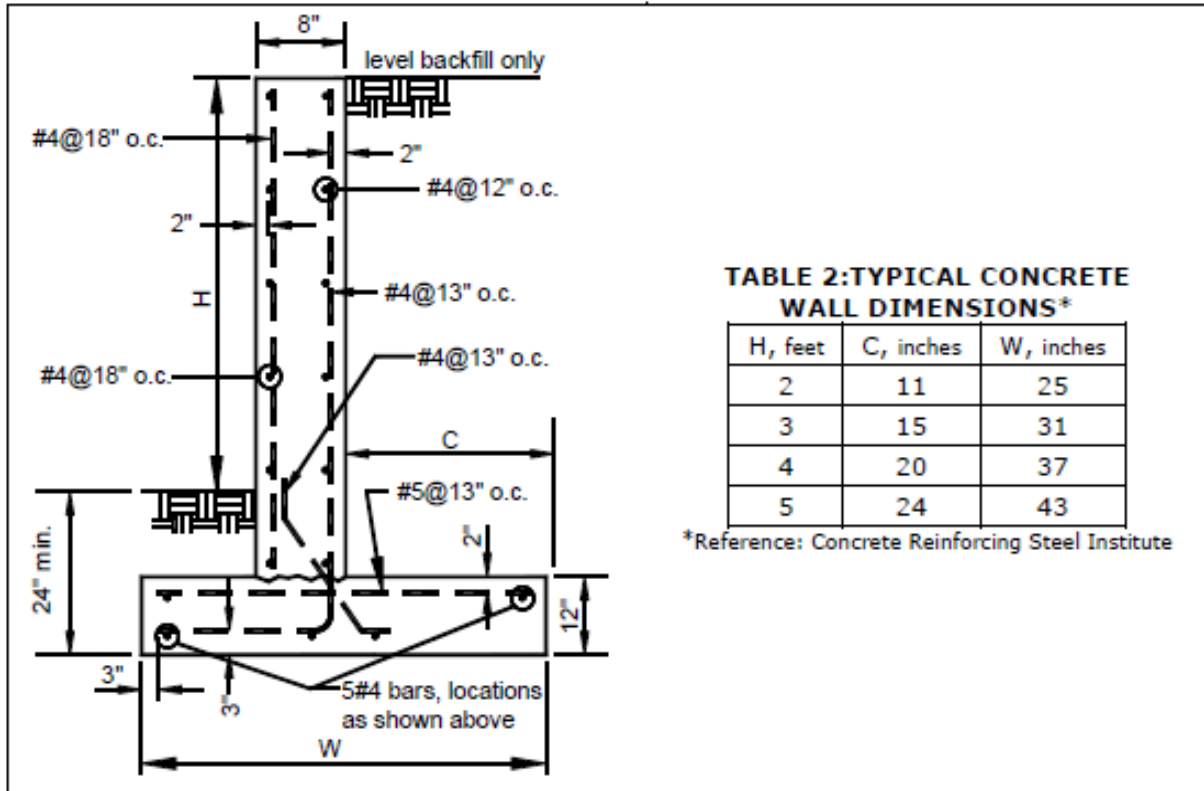

FIGURE 13: TYPICAL CONCRETE WALL SECTION

DOWEL AND KEYWAY REQUIREMENTS:

Dowels, #4@13" o.c., must be lapped a minimum of 20 inches. A keyway or roughened concrete shall be placed on the footing surface below the block wall. See FIGURE 14.

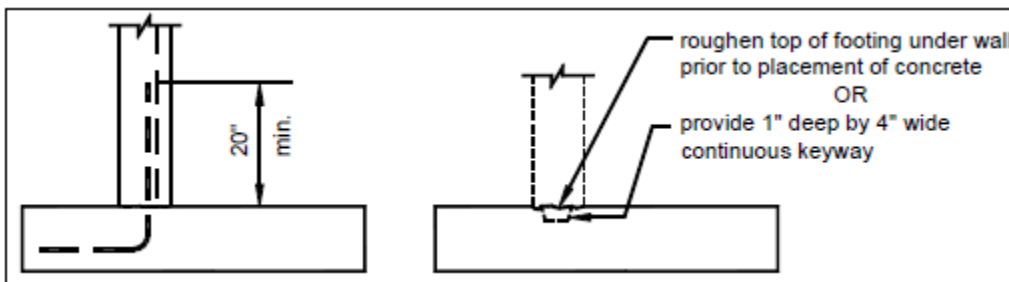

FIGURE 14: TYPICAL DOWEL AND KEYWAY DETAIL

VERTICAL JOINT REQUIREMENTS:

Control joints, constructed per FIGURE 15, shall be placed no more than 20 feet on center. Expansion joints, constructed per FIGURE 16, shall be placed at every fourth control joint.

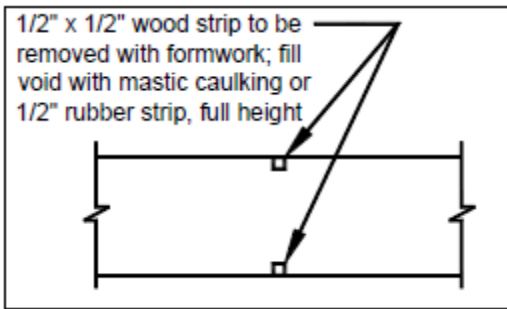

FIGURE 15: TYPICAL CONTROL JOINT DETAIL

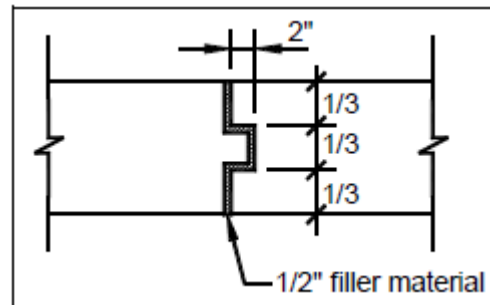

FIGURE 16: TYPICAL EXPANSION JOINT DETAIL

BACKFILL AND DRAINAGE REQUIREMENTS:

Backfilling against reinforced concrete retaining walls shall not be permitted until the concrete has reached its 28-day strength. Heavy equipment shall maintain a distance away from the wall equal to the wall's height. Care shall be taken to avoid exerting large impact forces on the wall.

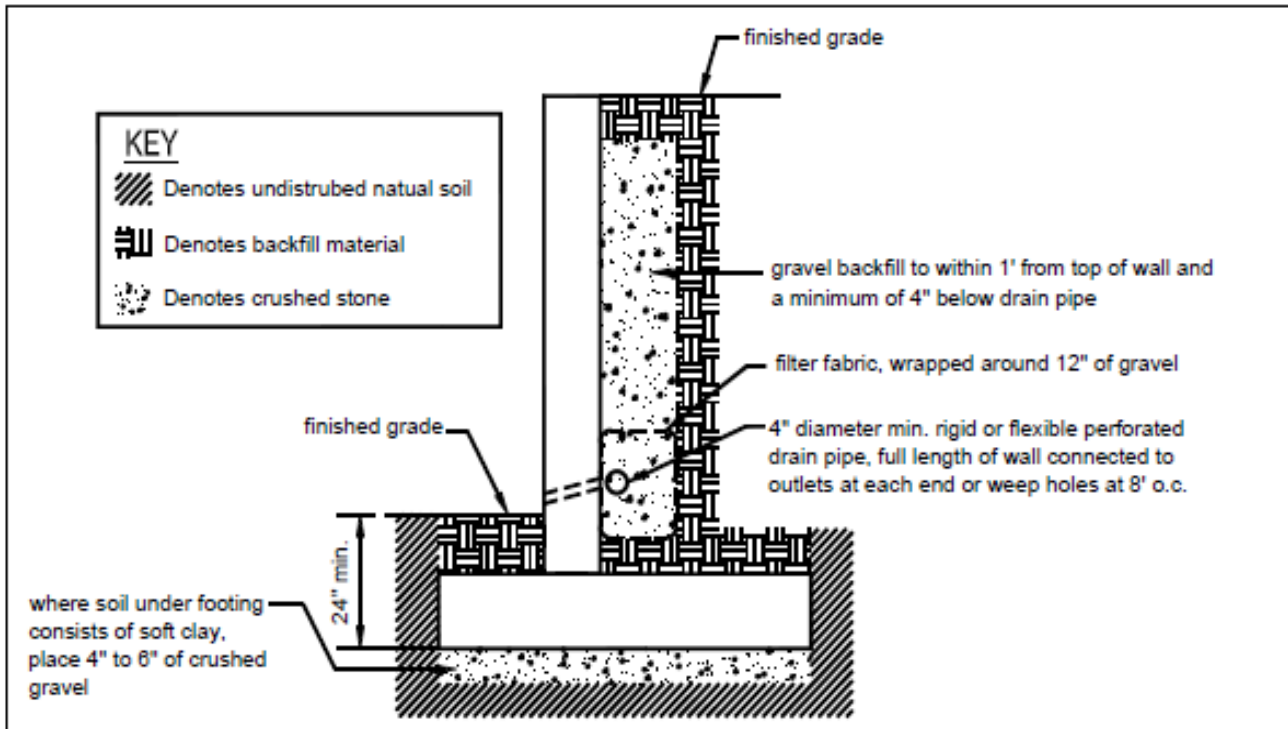

FIGURE 17: TYPICAL BACKFILL AND DRAINAGE DETAIL

APPENDIX A:

CONTACT INFORMATION

City of Alexandria Code Administration
301 King Street, Room 4200
Alexandria, Virginia 22314
703-838-4360

24 hour automated inspections request ACCESS line.
City of Alexandria Automated Computerized Code Enforcement Scheduling System (ACCESS) [for inspectors]
703-838-4900

City of Alexandria Dept. of Transportation and Environmental Services (T&ES)
301 King Street, Room 4130
Alexandria, Virginia 22314
703-746-4035

City of Alexandria Dept. of Planning and Zoning
301 King Street, Room 2100
Alexandria, Virginia 22314
703-746-4666

City of Alexandria Board of Architectural Review (BAR)
301 King Street, Room 2100
Alexandria, Virginia 22314
703-746-3833

“Miss Utility”
1-800-552-7001

Land Records Office
City of Alexandria Court House
520 King Street - Suite 307
Alexandria Virginia 22314
703-746-4066